

SHRI S'AD VIDYA MANDAL INSTITUTE OF TECHNOLOGY, BHARUCH
DEPARTMENT OF MECHANICAL ENGINEERING



By Ashish J. Modi

STEAM BOILER



INTRODUCTION

- **Boiler – a device used to generating steam from water.**
- **Steam is utilized for power generation, for process heating or for space heating.**
- **According to IBR (Indian Boiler Regulation), a boiler is a closed pressure vessel with capacity exceeding 22.75 litres used for generating steam under pressure.**

Essential Qualities

1. Should produce maximum steam with minimum fuel consumption.
2. Should be able to deliver desired quantity of steam quickly after starting.
3. Should be able to meet large load fluctuation.
4. Should be light and simple in construction.
5. Should occupy less space.
6. Should be easy to maintain and inspect

Essential Qualities

- 7. Joints should be accessible for inspection and should not face the impact of flame directly.**
- 8. Velocity of water and that of flue gases should be minimum.**
- 9. Tubes should be sufficiently strong to resist wear and corrosion.**
- 10. Mud and other deposits should not collect on heated plates.**
- 11. Should as per regulation given by IBR.**

Classification

- 1. According to Relative Position of Water and Hot gases:**
 - 1. Fire Tube Boilers**
 - 2. Water Tube Boilers**
- 2. According to Geometric Orientation:**
 - 1. Horizontal Boilers**
 - 2. Vertical Boilers**
- 3. According to Location of Furnace:**
 - 1. Externally Fired Boilers**
 - 2. Internally Fired Boilers**

Classification

4. According to Method of Water Circulation

- **Natural Circulation Boilers:** water convection currents are set up due to temperature difference. water from steam drum falls under gravity to header where its temperature rises and density reduces. So it travels upwards to steam drum through evaporator

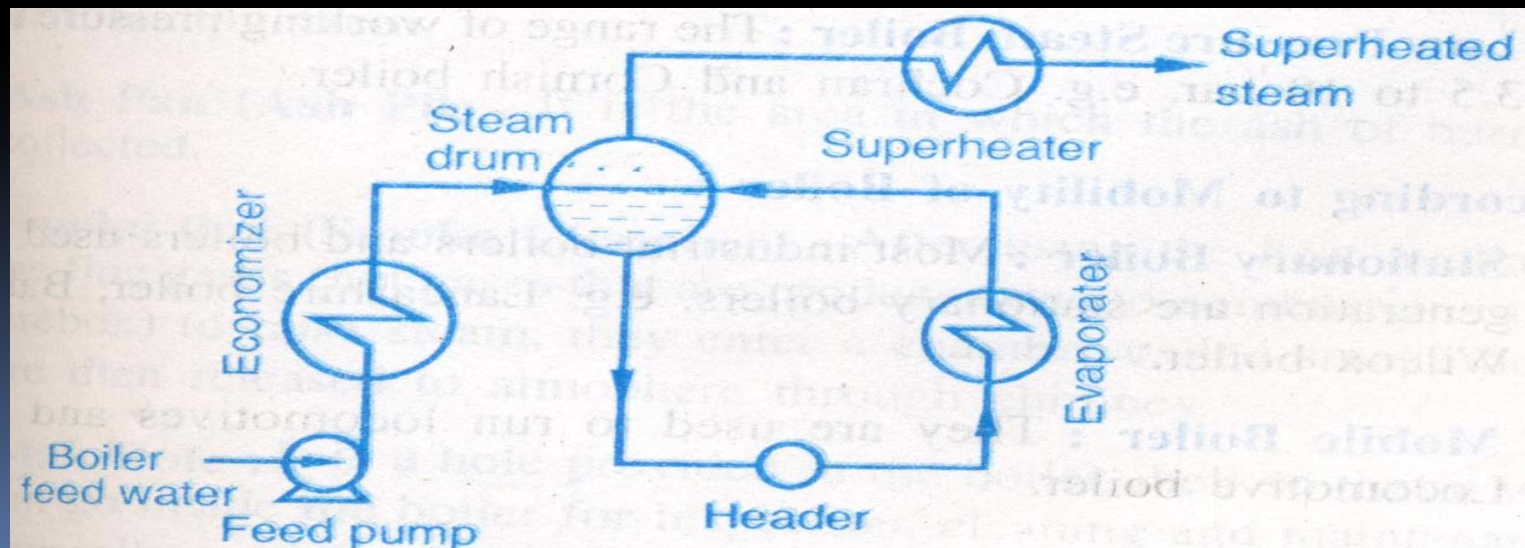

Classification

- **Forced Circulation Boilers:** water is circulated through boiler circuit by a pump. Low capacity boilers use natural circulation, while only high pressure-high capacity boilers use forced circulation.

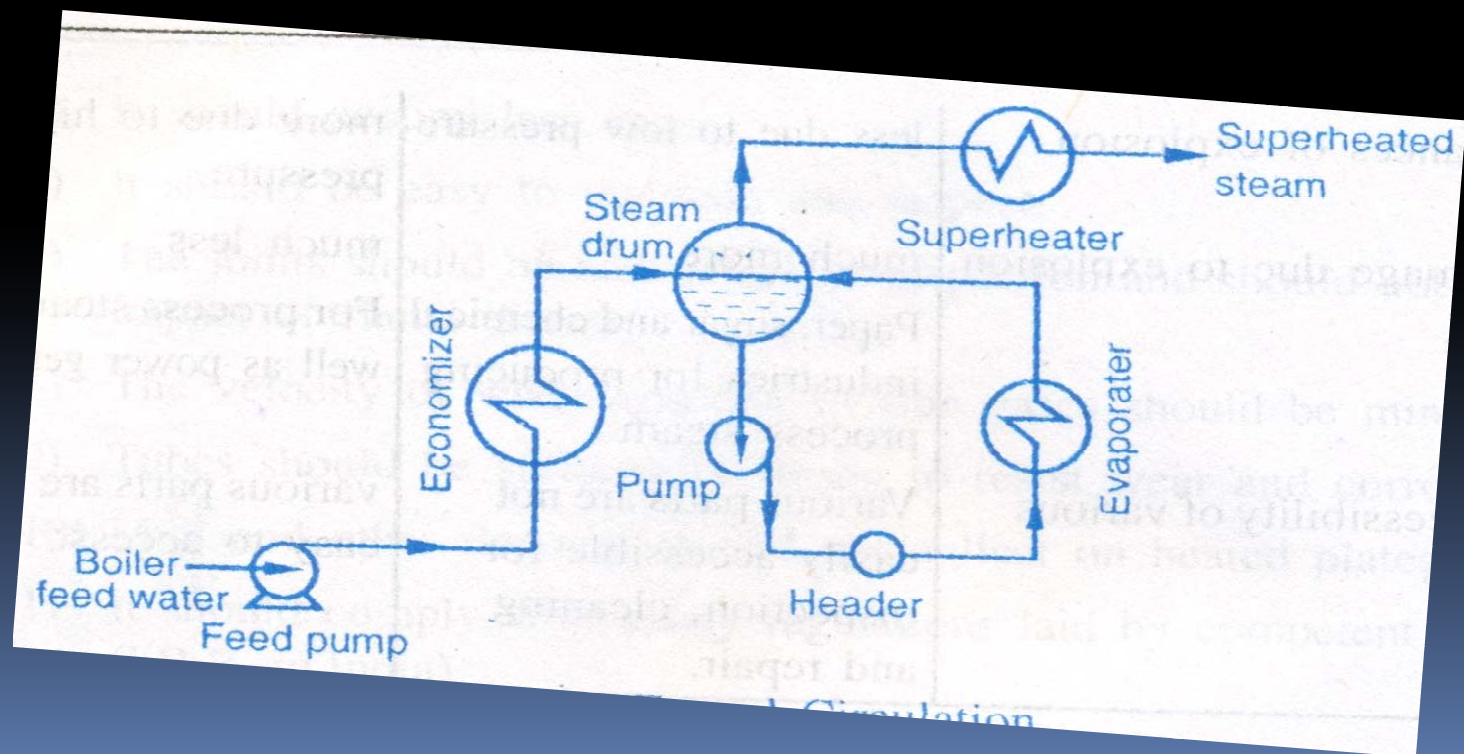

Classification

5. According to Magnitude of working Pressure:

1. High Pressure Steam Boilers > 25 bars
e.g. Babcock and Wilcox Boilers
2. Medium Pressure Steam Boilers – 10-25 bars
e.g. Lancashire and Locomotive Boilers
3. Low Pressure Steam Boilers – 3.5-10 bars
e.g. Cochran and Cornish Boilers

Classification

6. According to Mobility of Boiler:

1. Stationary Boilers

e.g. Lancashire Boilers,
Babcock and Wilcox Boilers

2. Mobile Boilers

e.g. Locomotive Boilers

Factors affecting the Selection of a boiler

1. Type of steam to be produced. i.e. wet, dry and superheated steam.
2. Steam generating rate and steam pressure required.
3. Quality and quantity of fuel and water available.
4. Cost of installation and erection.
5. Cost of operation and maintenance.
6. Availability of floor space.
7. Probable load factor.

Parts of a Boiler

1. **Cylindrical Shell**
2. **Grate**
3. **Fire Hole**
4. **Fire Box**
5. **Ash Pan (Ash Pit)**
6. **Smoke Box (Smoke Chamber)**
7. **Man Hole**
8. **Hand Hole**

Parts of a Boiler

9. Mud Box

10. Steam Collecting Pipe

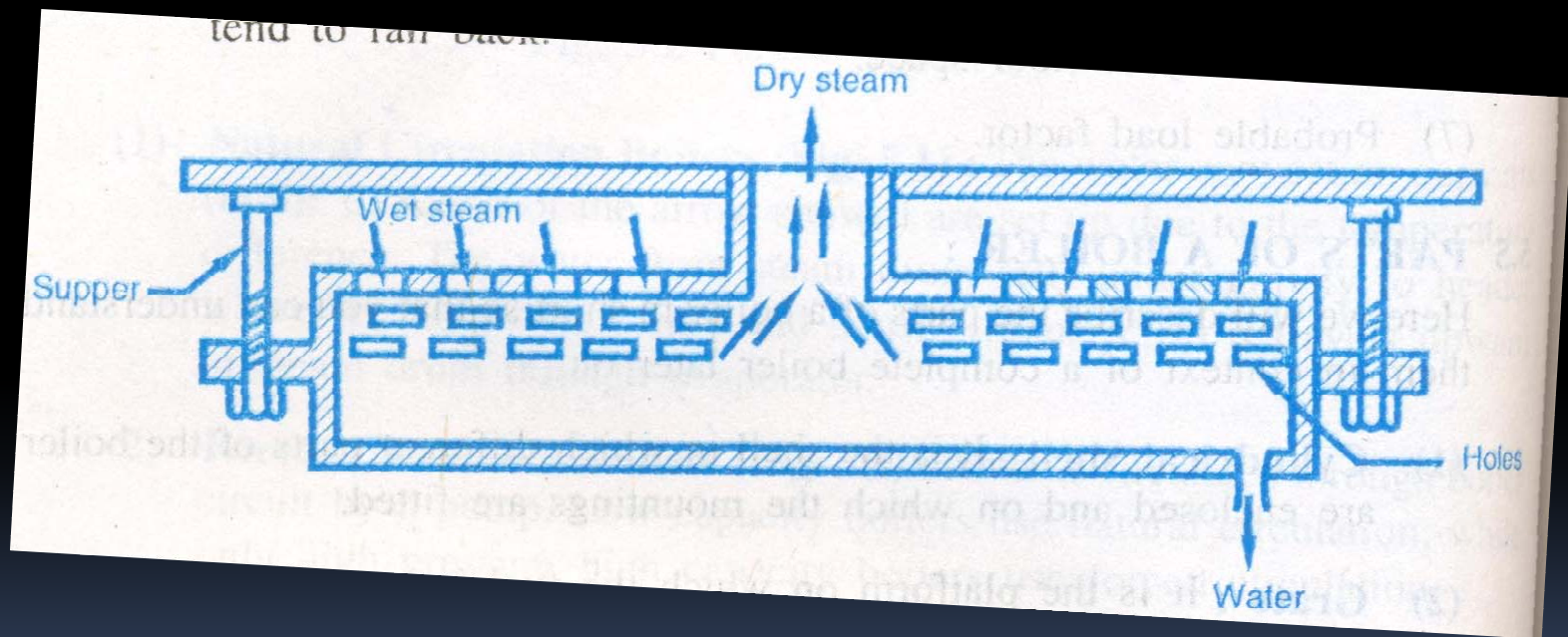

11. Boiler Stays

12. Flue and Fire Tube

Boilers

Simple Vertical Boiler

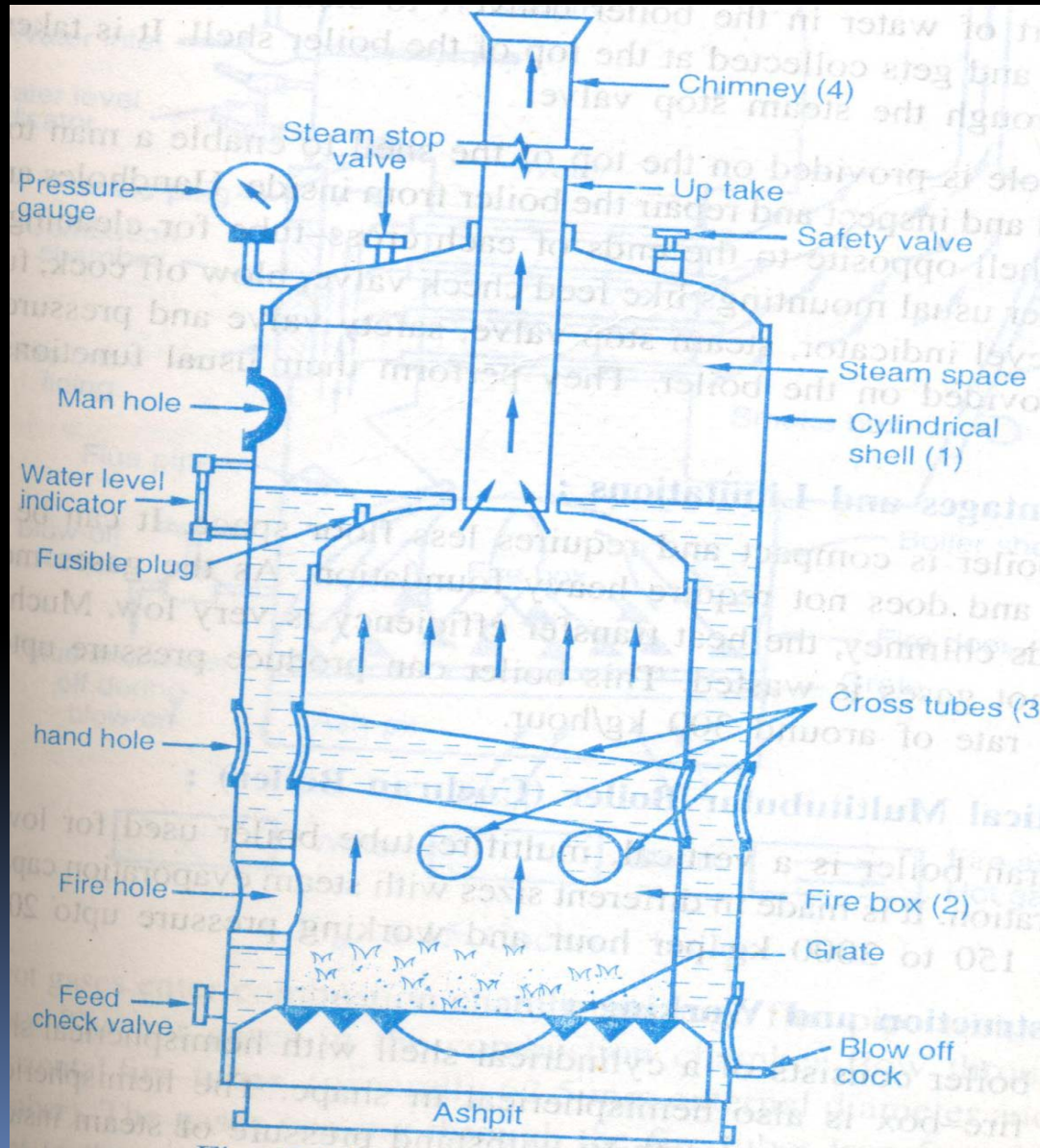

Simple Vertical Boiler

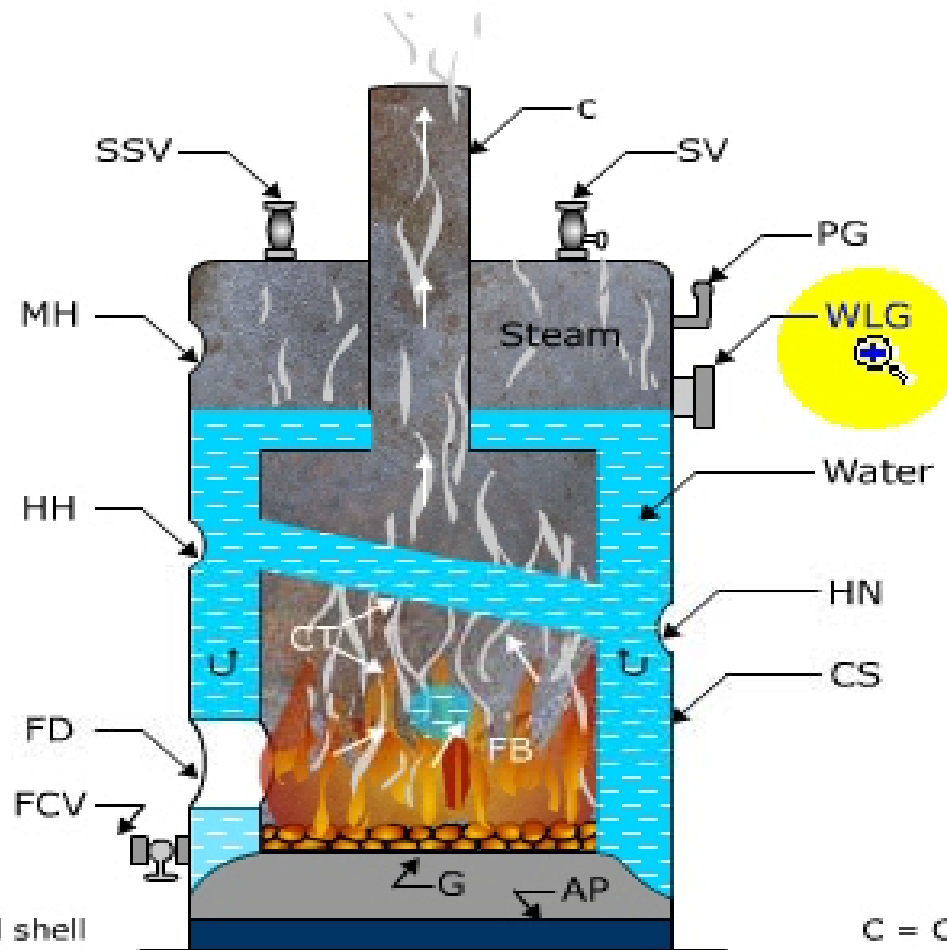

CS = Cylindrical shell
 MH = Man hole
 CT = Cross tubes
 G = Grate
 PG = Pressure gauge
 SV = Safety valve
 WLG = Water level gauge

C = Chimney
 HH = Hand hole
 FD = Fire door
 FB = Fire box
 AP = Ash pit
 SSV = Steam stop valve
 FCV = Feed check valve

Advantages and Limitations

- Compact and requires less floor space.
- Transported easily and not require heavy foundation.
- As the gases move directly towards chimney, heat transfer efficiency is very low. Much of the gas with hot gases is wasted.
- Can produce up to 7 bar and steam rate around 300 kg/hr.

Cochran Boiler

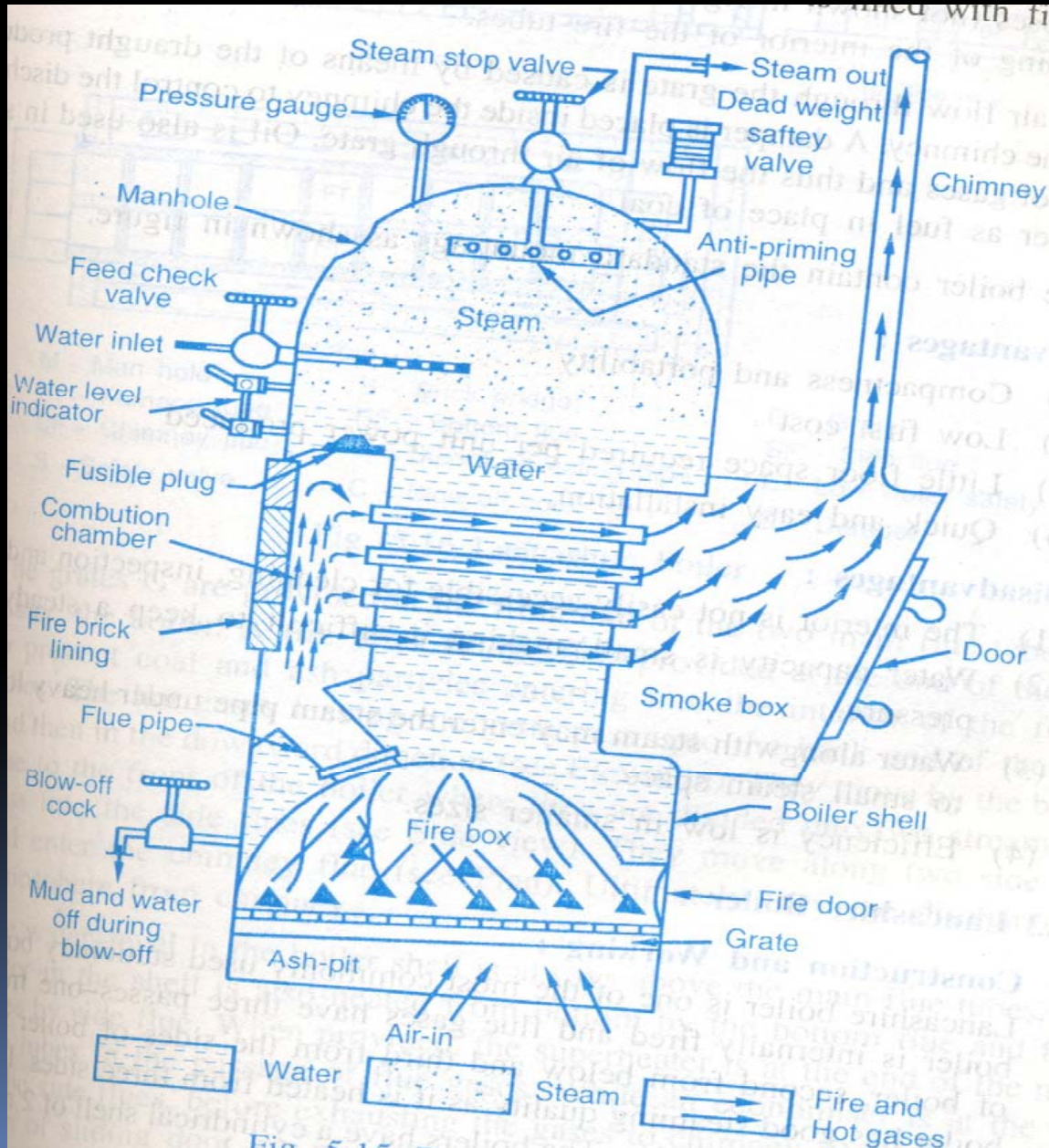

Cochran Boiler

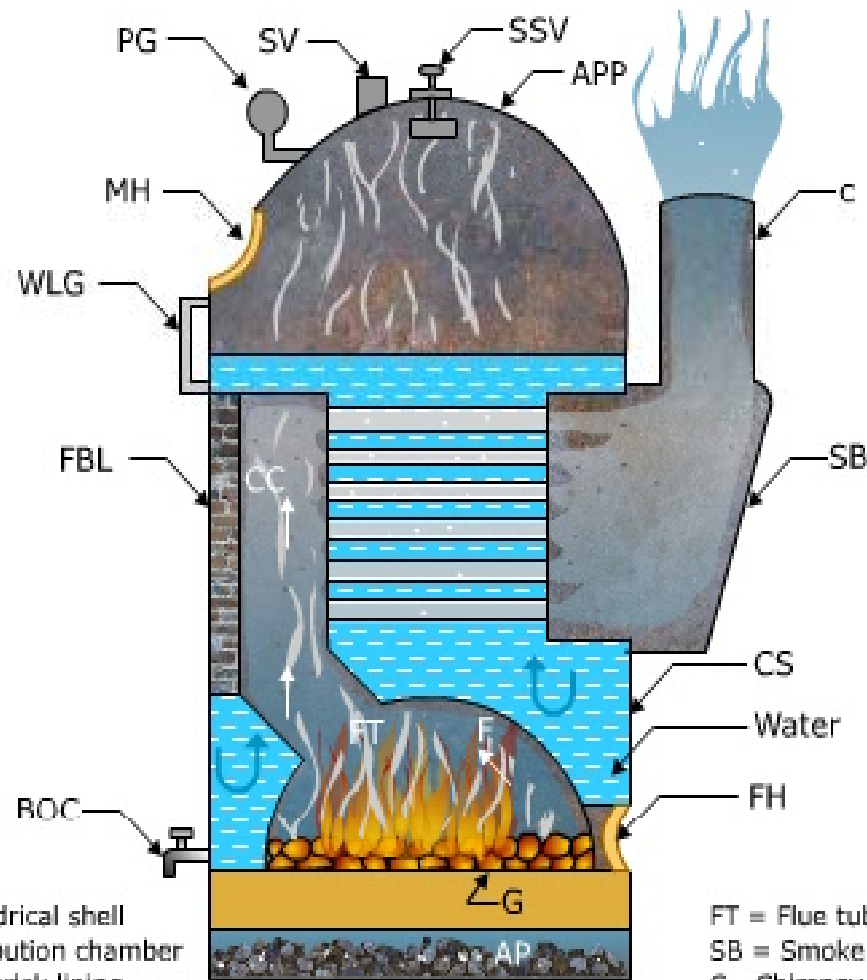

CS = Cylindrical shell
 CC = Combustion chamber
 FBL= Fire brick lining
 F = Furnace
 BOC=Blow off cock
 SSV=Steam stop valve
 APP = Antipriming pipe
 PG =Pressure gauge

FT = Flue tube
 SB = Smoke box
 C= Chimney
 FH = Fire hole
 G = Grate
 AP=Ash pit
 SV=Safety valve
 MH = Manhole
 WLG = Water level gauge

Cochran boiler

Advantages

- **The minimum floor area is required. (compact boiler)**
- **Cost of construction is low.**
- **It can be moved and setup readily in different locations.**
- **Boiler has self contained furnace. No brick work setting is necessary.**
- **Any type of fuel can be used.**

Disadvantages

- **Steam raising capacity is less due to vertical design.**
- **Difficulty in cleaning and inspection due to vertical design.**
- **The capacity and pressure are limited.**
- **The boiler requires high head room.**

Lancashire Boiler

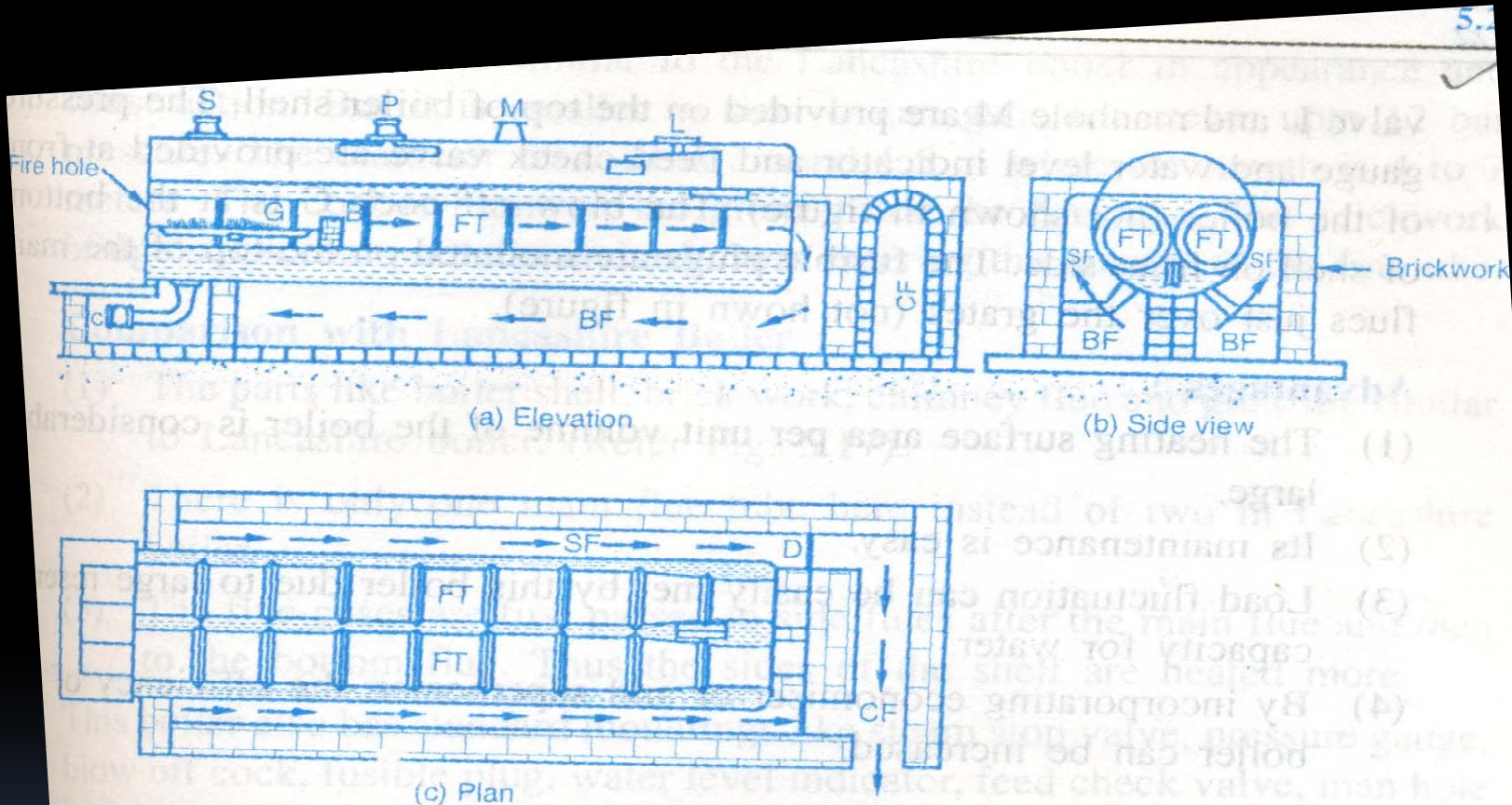

- | | | |
|-------------------|---------------------------|----------------------------|
| M - Man hole | B - Brick bridge | G - Grate |
| FT - Furnace tube | BF - Bottom flue | SF - Side flue |
| CF - Chimney flue | P - Steam collecting pipe | L - Low water safety valve |
| S - Safety valve | C - Blow-off cock | D - Damper |

Fig. 5.16 Lancashire boiler

The grates G are provided

Advantages

- Heating area per unit volume is large.
- Its maintenance is easy.
- Load fluctuation can be easily met by this boiler due to large reserve capacity for water.
- By incorporating economizer or and superheater, the efficiency of the boiler can be increased.

Limitations

- Occupies large floor space due to brick work.
- Take more time to deliver steam at required pressure and rate.
- Grates are inside the flue tubes. So their area is restricted.
- Maximum pressure is limited to around 15 bar due to shell construction.

Cornish Boiler

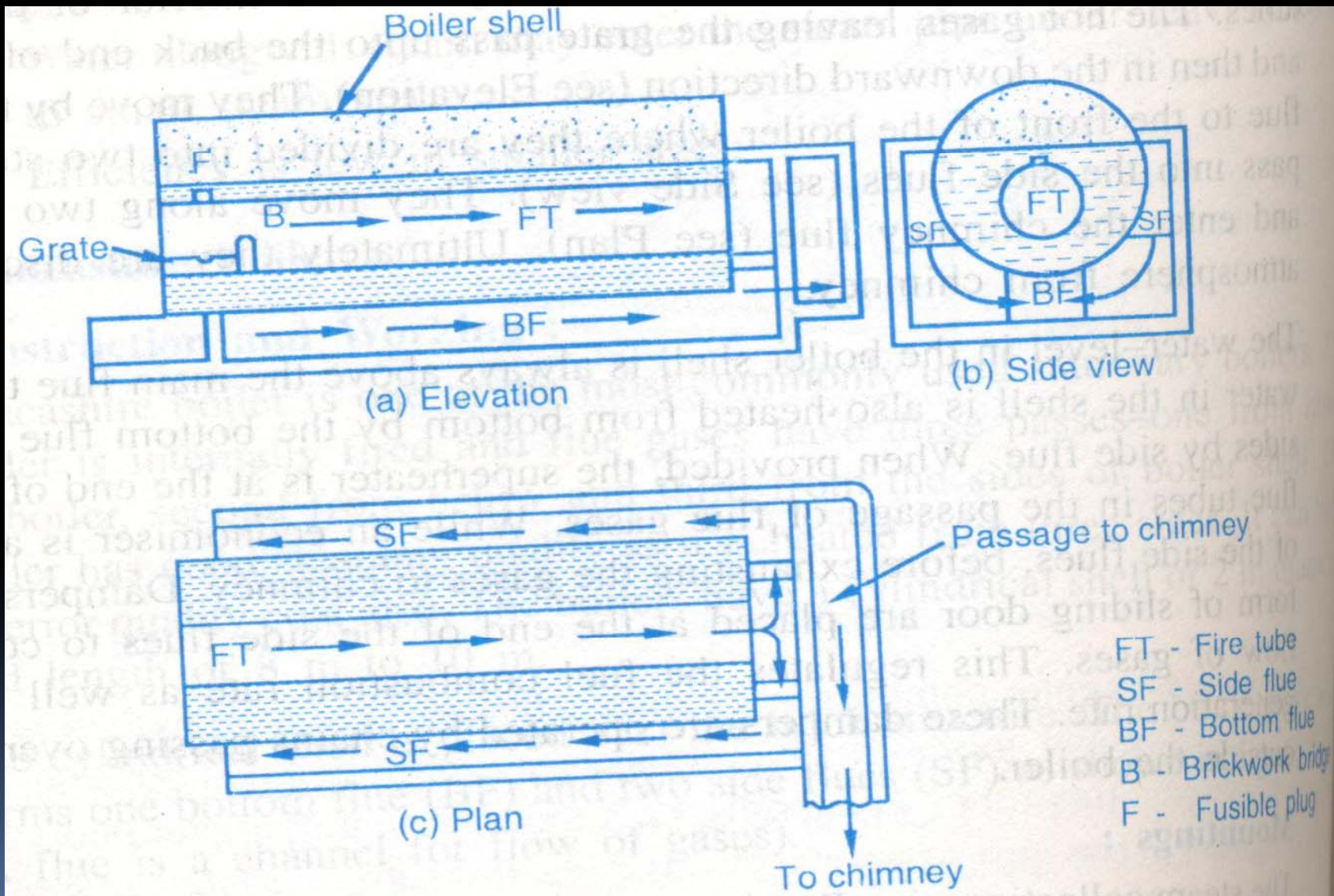

Comparison with Lancashire

- The parts like boiler shell, brick work, chimney flue and grate are similar to Lancashire boiler.
- There is only one main flue tube here instead of two in Lancashire boiler.
- The flue gases are first passed to side flues after the main flue and then to the bottom flue. Thus the sides of the shell are heated more.

Locomotive Boiler



Locomotive Boiler

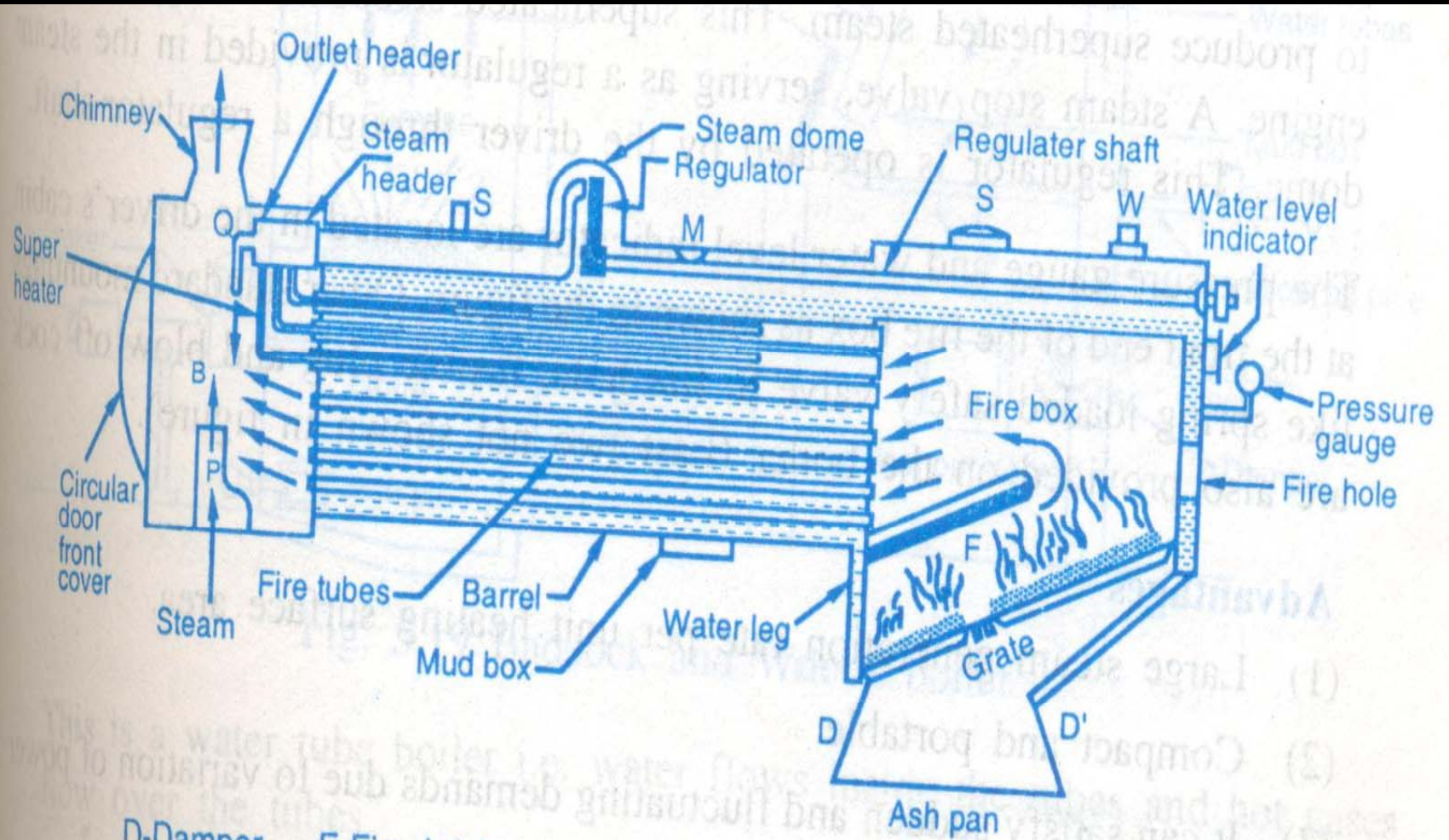

D-Damper, F-Fire brickarch, S-Steam safety valve, Q-Steam pipe,
 B-Smoke-box, P-Blast pipe, M-Man hole

Locomotive Boiler

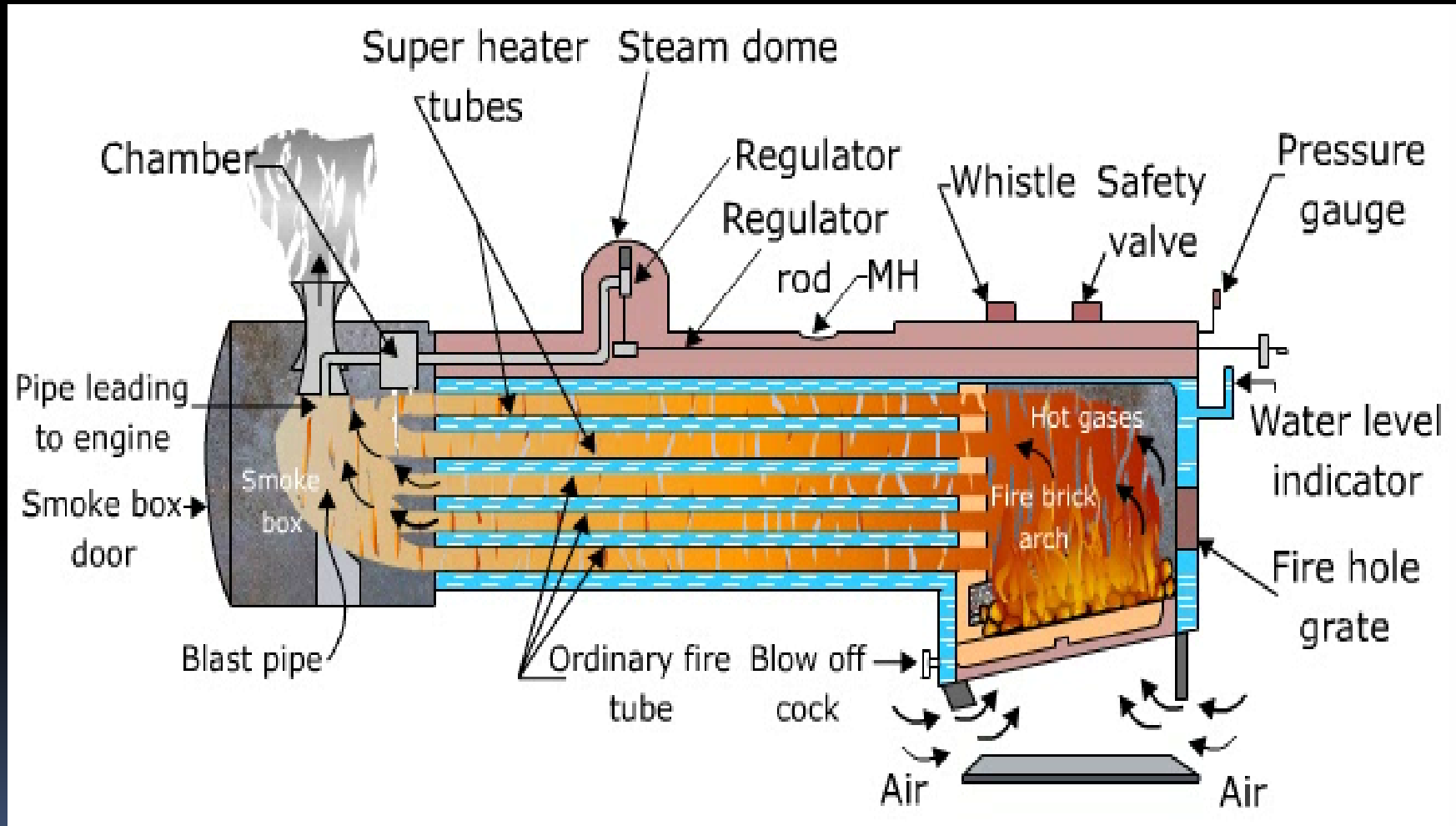

Advantages

- Large steam generation rate per unit heating surface area.
- Compact and portable.
- Can satisfy sudden and fluctuating demands due to variation of power and speed.

Disadvantages

- Sediments and mud particles may accumulate in the narrow water spaces which may lead to scale formation and corrosion.
- Difficult to clean some water spaces.
- Leakage at tube joints and plates is a problem.

Babcock and Wilcox Boiler

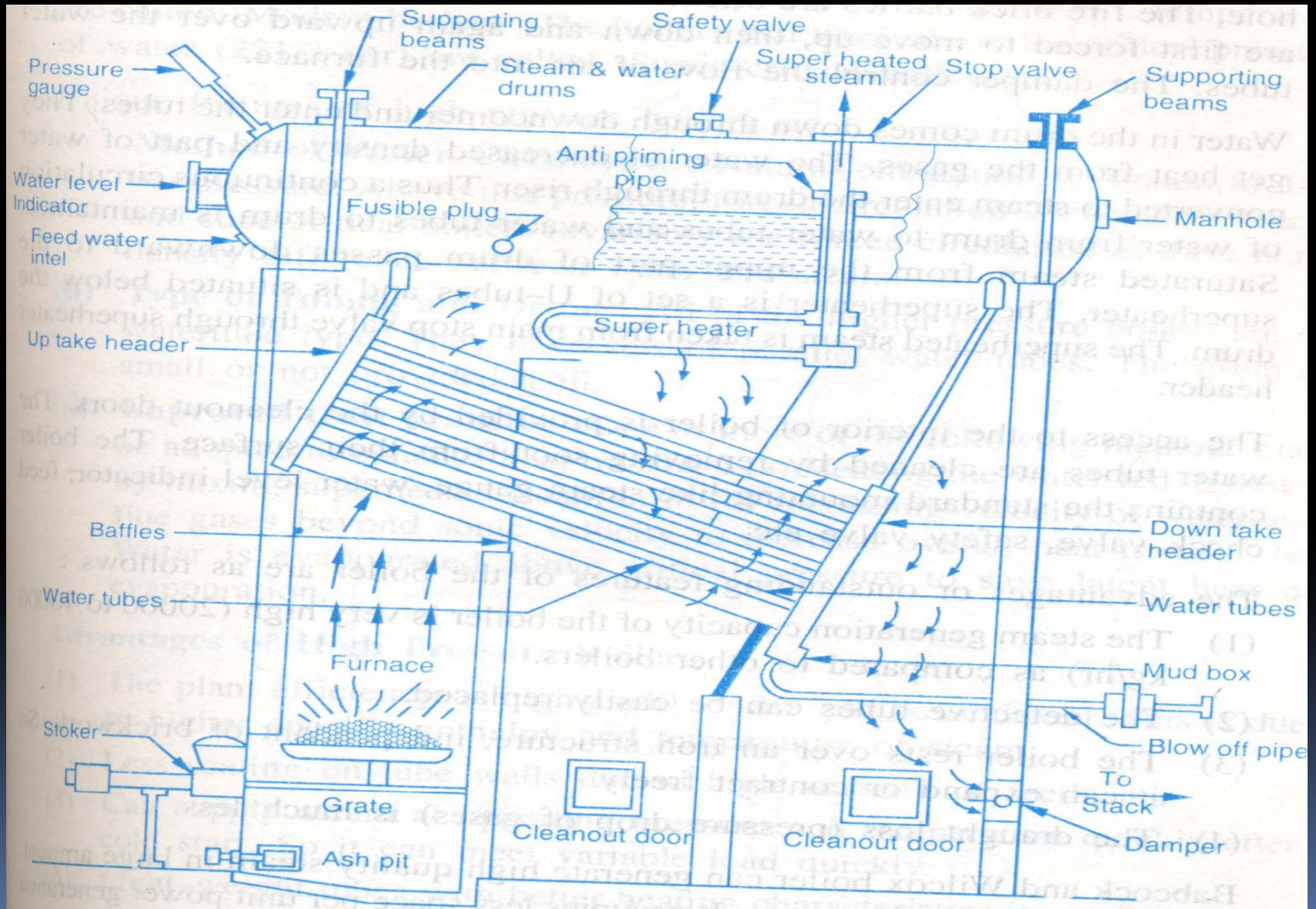

Babcock and Wilcox Boiler

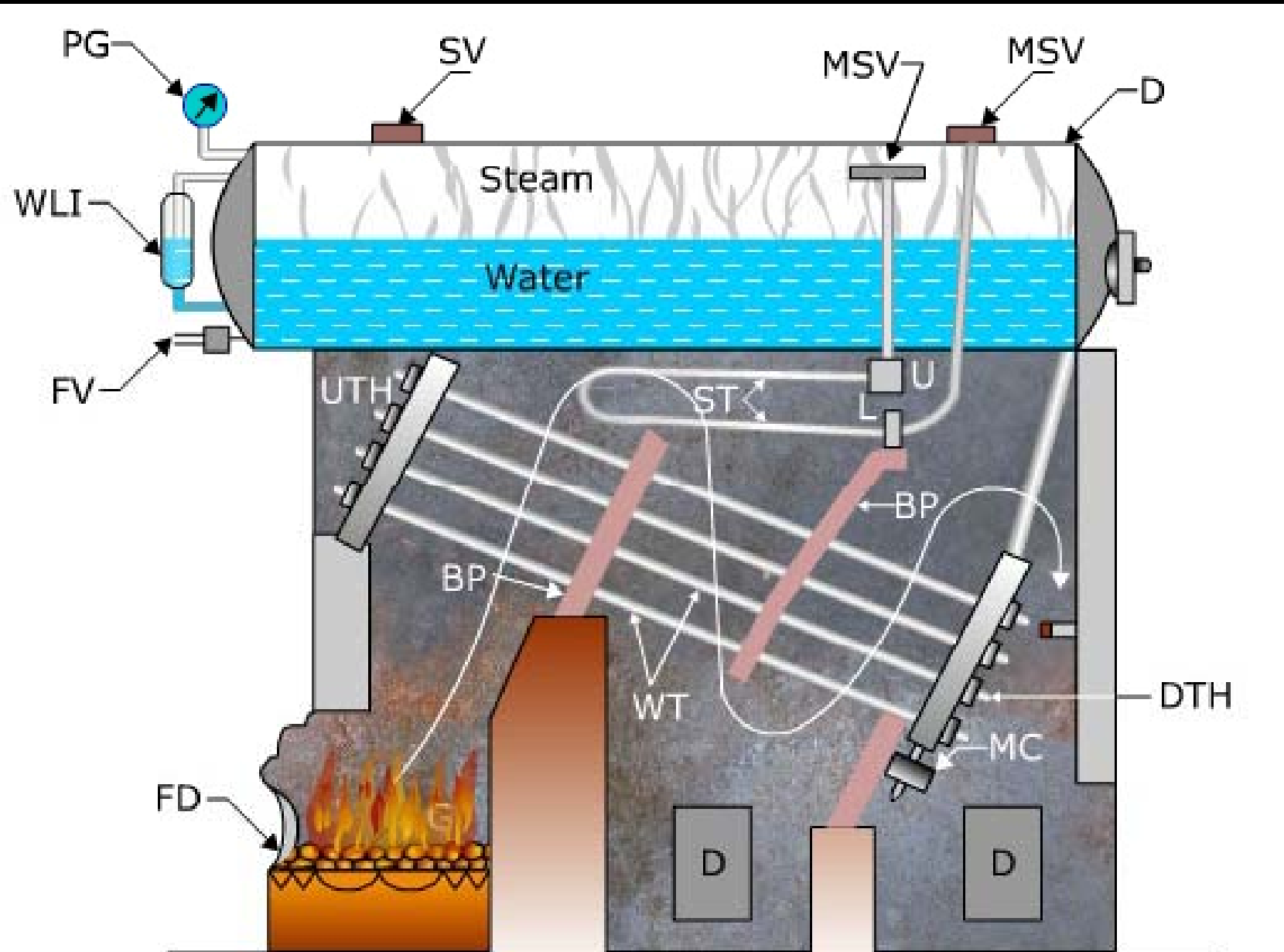

Advantages

- Capacity is very high (20,000 to 40,000 kg/hr).
- Defective tubes can easily replaced.
- Boiler rests over an iron structure, independent of brickwork. So it can expand or contract freely.
- Draught loss (pressure drop of gases) is much less.

Boiler Mountings

Boiler Mountings

Mountings	Function
1. <u>Steam Pressure Gauge</u>	To read steam pressure
2. <u>Water Level Indicator</u>	To find out water level in boiler
3. <u>Dead weight safety valve</u>	For boiler safety
4. <u>Feed check valve</u>	To feed water in a boiler
5. <u>Blow off cock</u>	For taking scale and other impurities from boiler and to empty the boiler when necessary.
6. <u>Steam stop valve</u>	To stop or allow the flow of steam from boiler.
7. Manhole	For periodic inspection
8. <u>Fusible plug</u>	To stop firing when the water level in the boiler is lower than safe limit.
9. Anti priming pump	To separate suspended moisture and allow passage of dry saturated steam through steam stop valve.

Steam Pressure Gauge

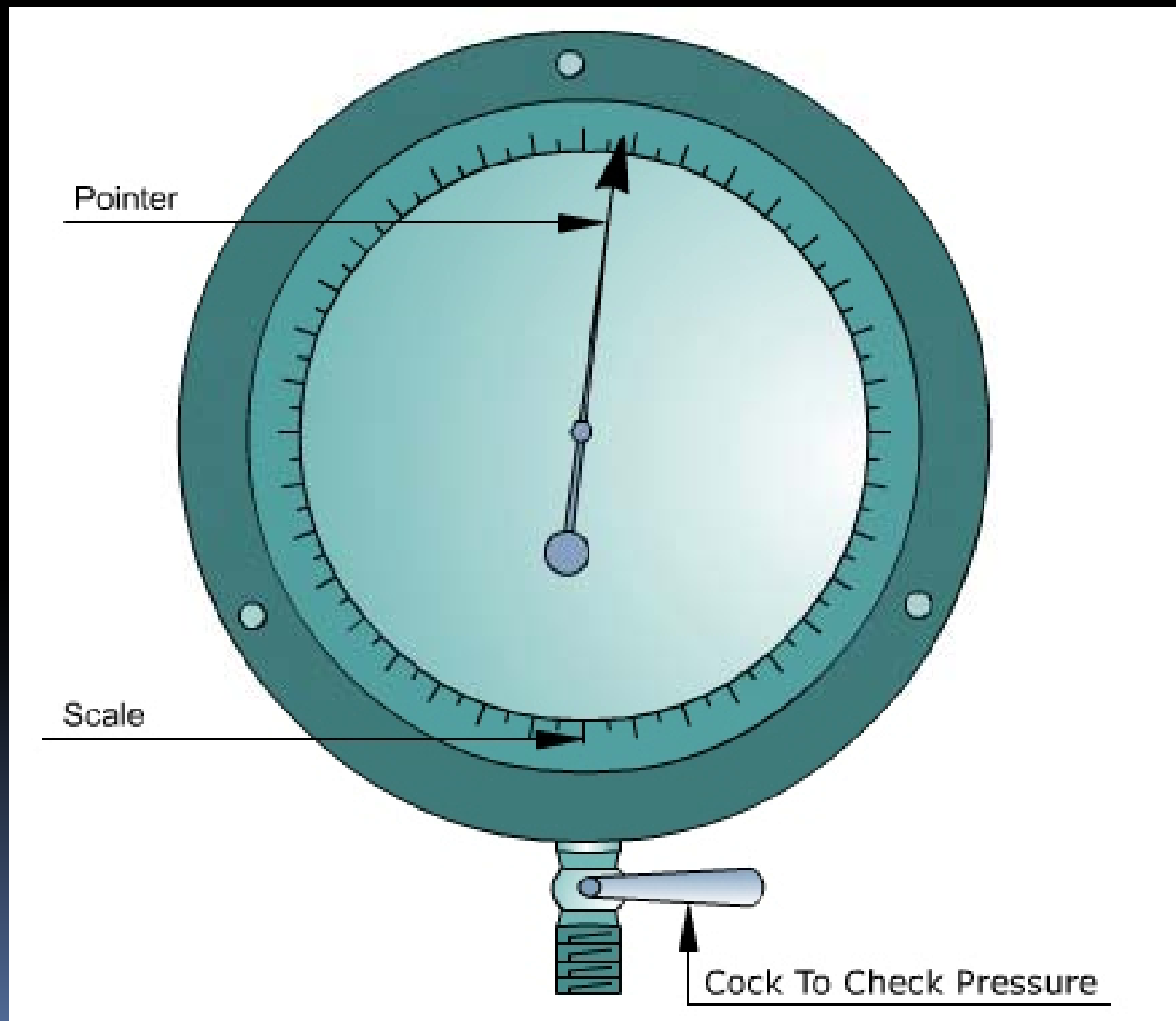

Water Level Indicator

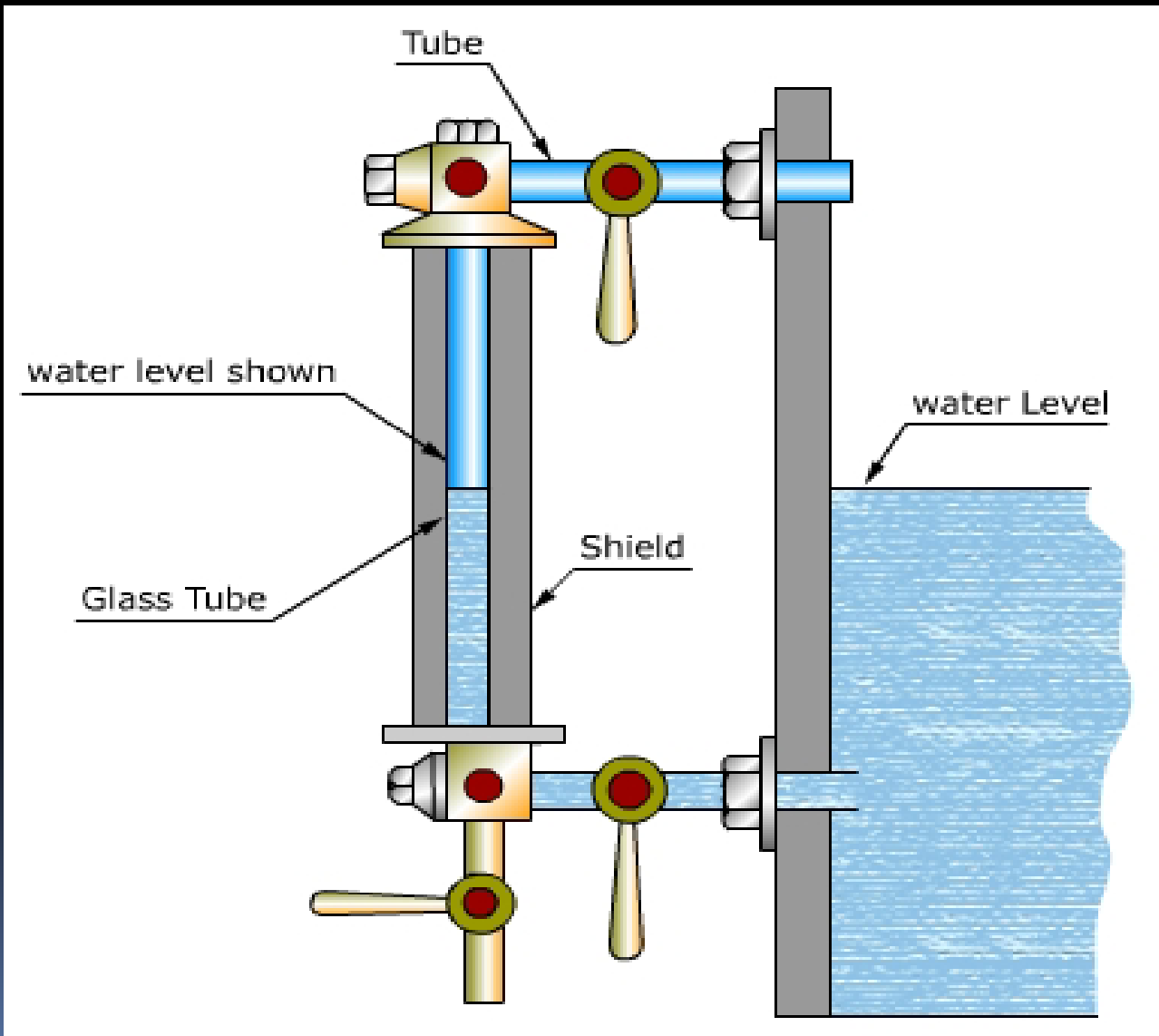

Dead Weight Safety Valve

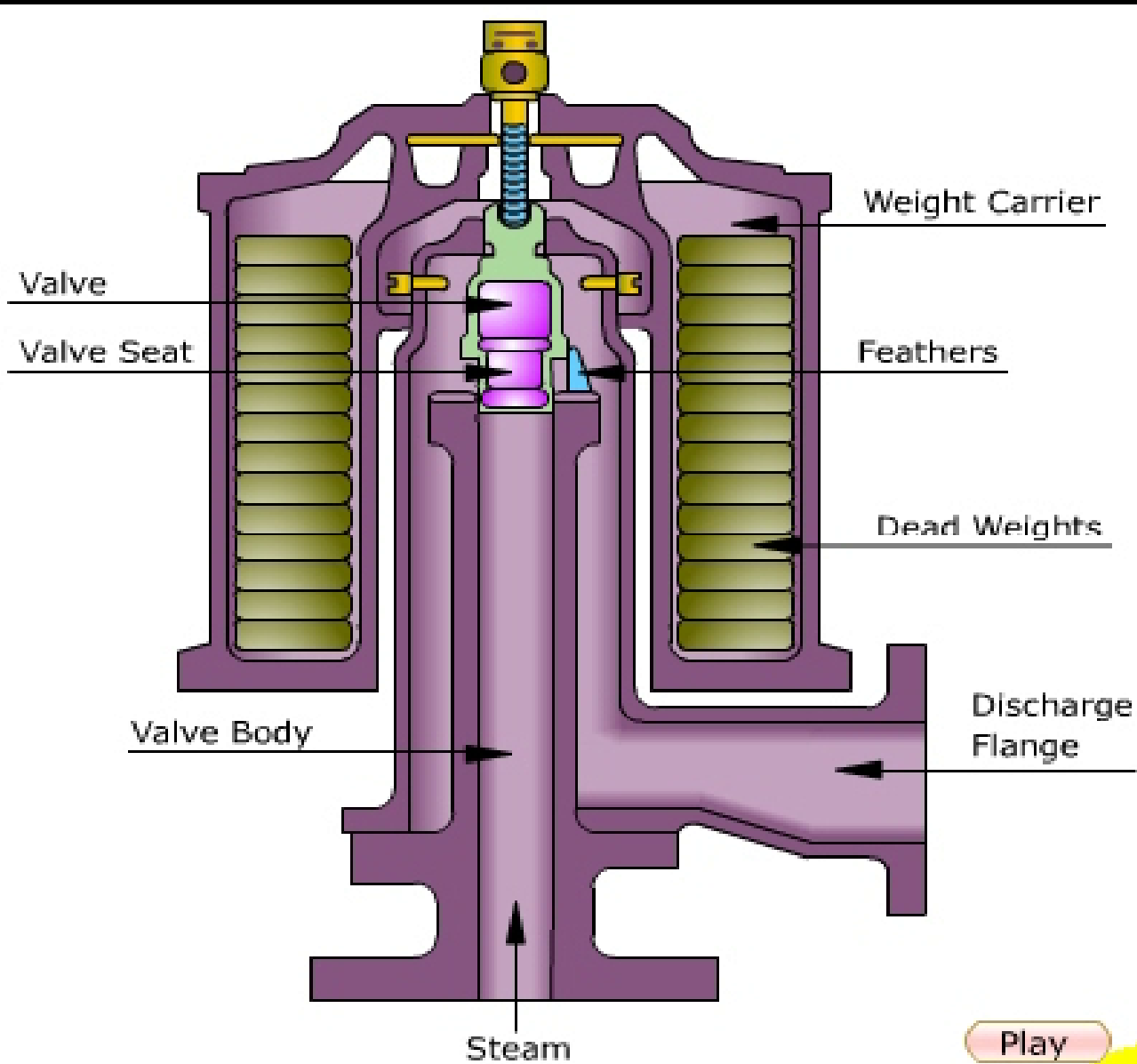

Play



Feed check valve

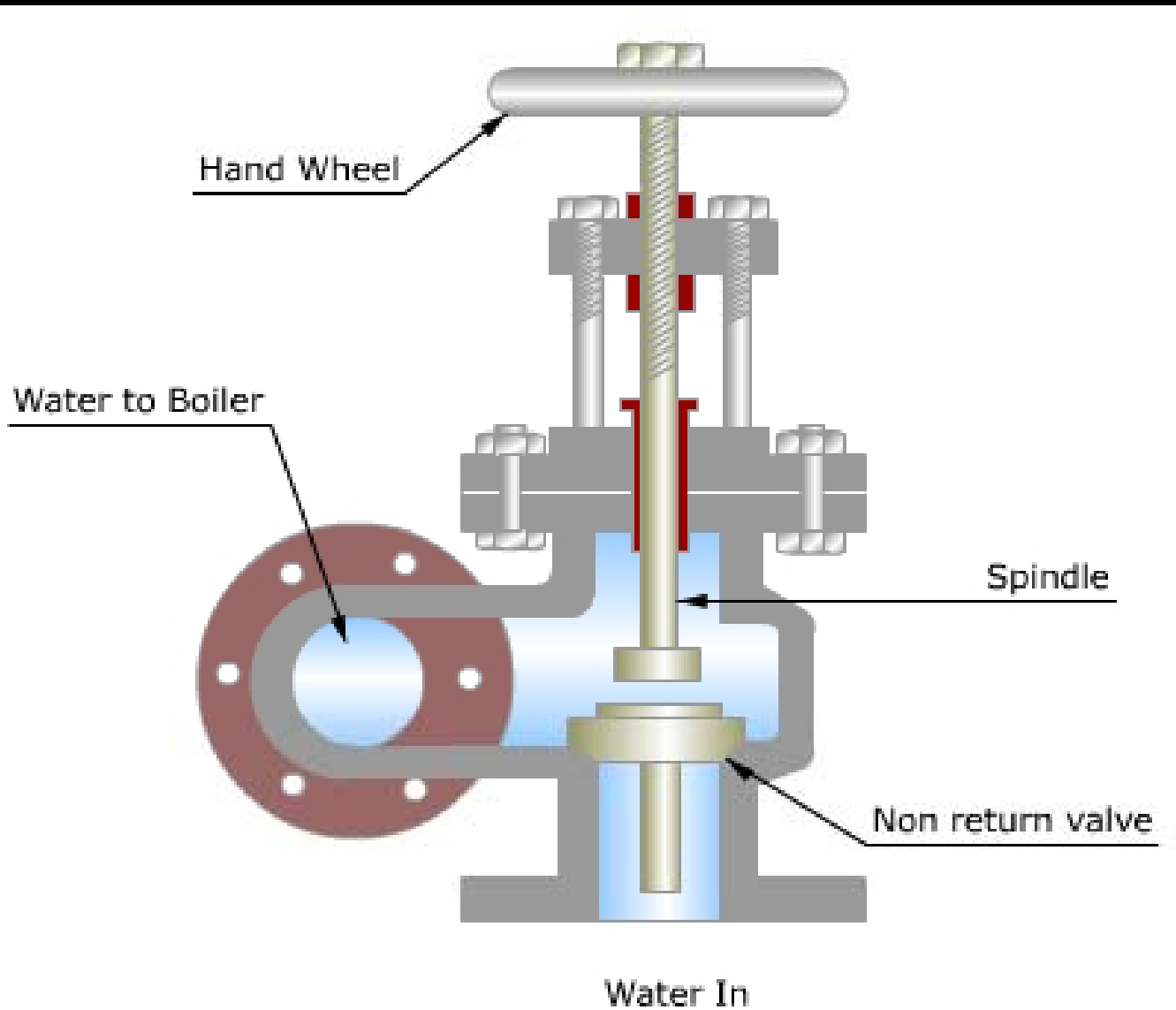

Blow off cock

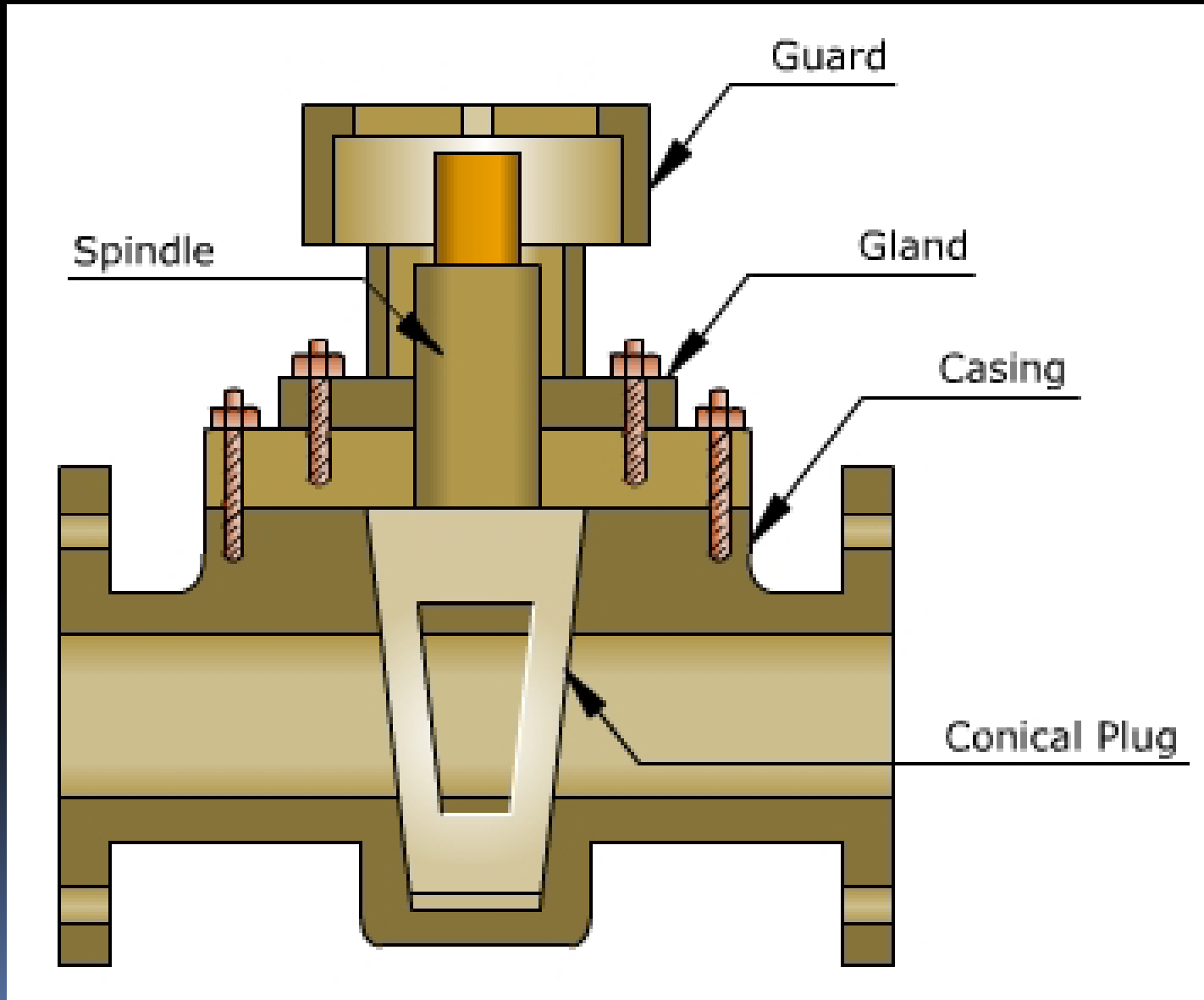

Steam stop valve

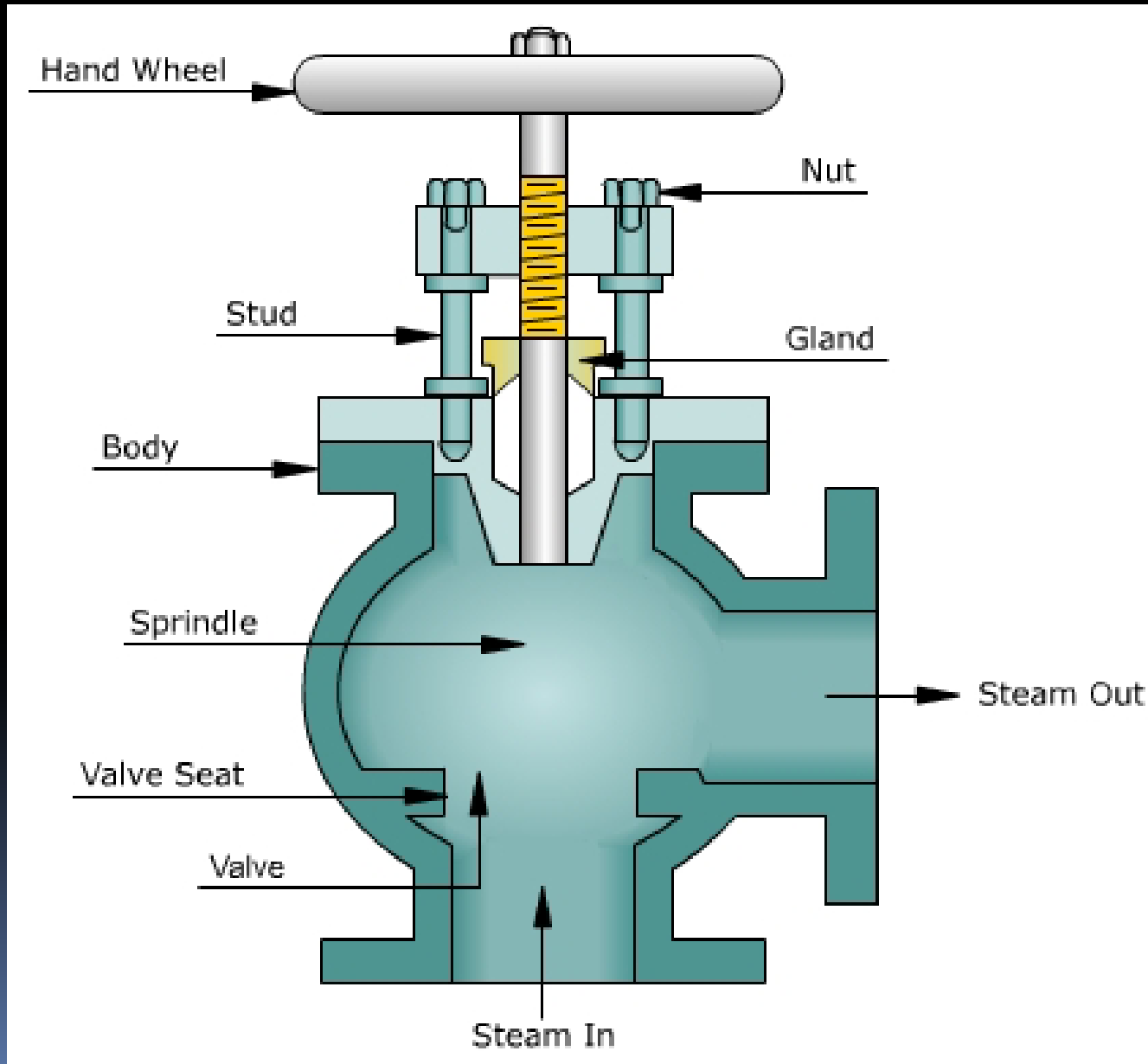

Fusible Plug

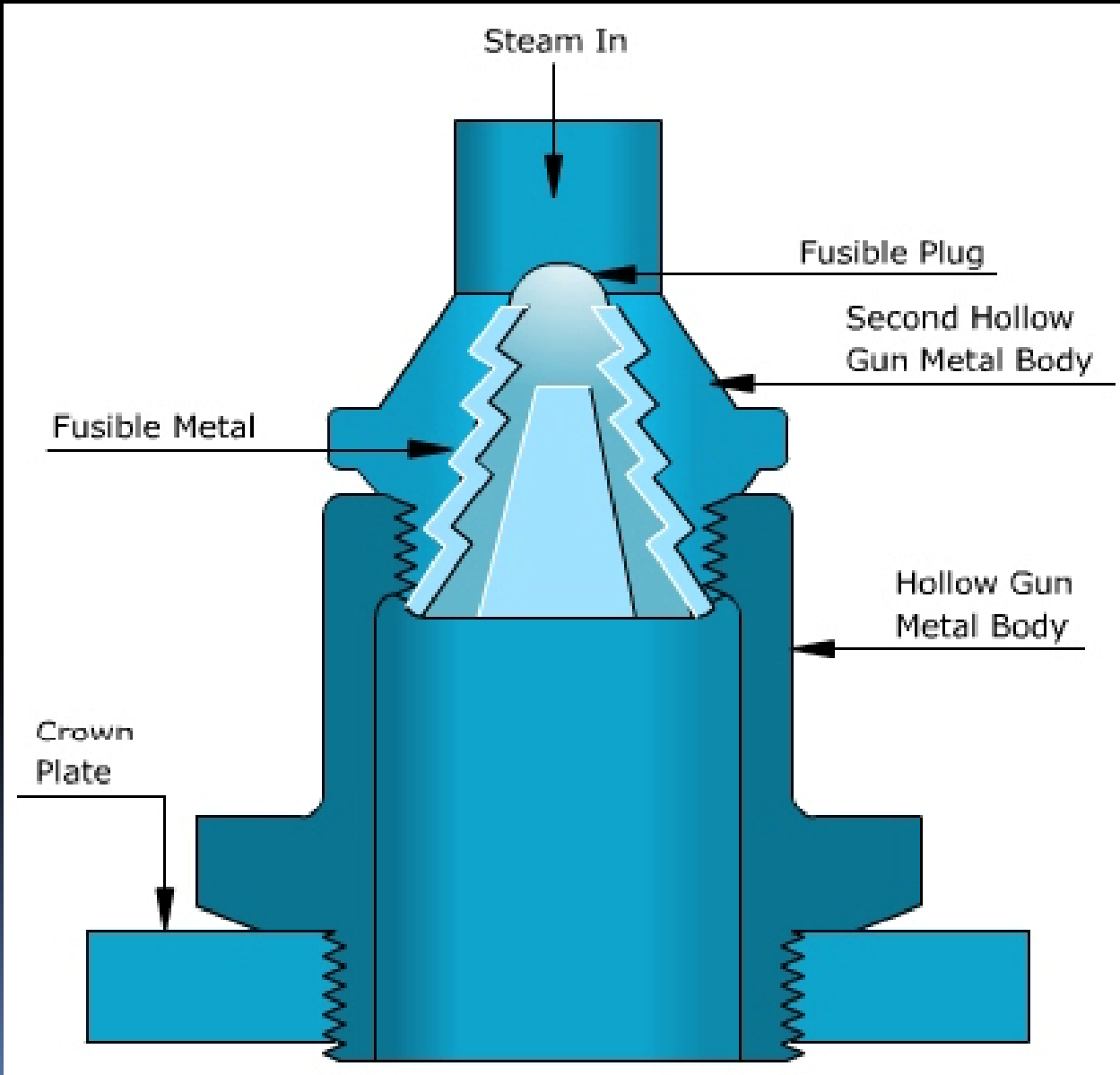



Thanks a lot...